







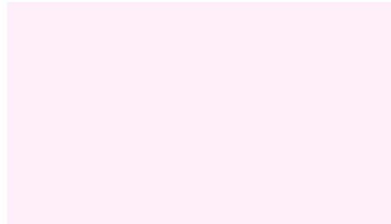

Toekomstig weg in het verlengde van de Elementenweg

Elementenweg

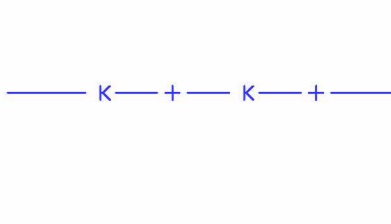

Radiumweg

VERKLARING

-  Asfalt verharding
-  Beton verharding
-  Vloestofdichte betonverharding
-  Groenstrook
-  Lavaliet
-  Hekwerk
-  Erfgrens
-  L.M. Lichtmast

Grens erfacht
 Oppervlakte: 41.642 m²
 Zone A: 4.600 m²
 Zone B: 37.042 m²
 opp. terrein binnen hekwerk 2927 m²

Situatie 1:2000

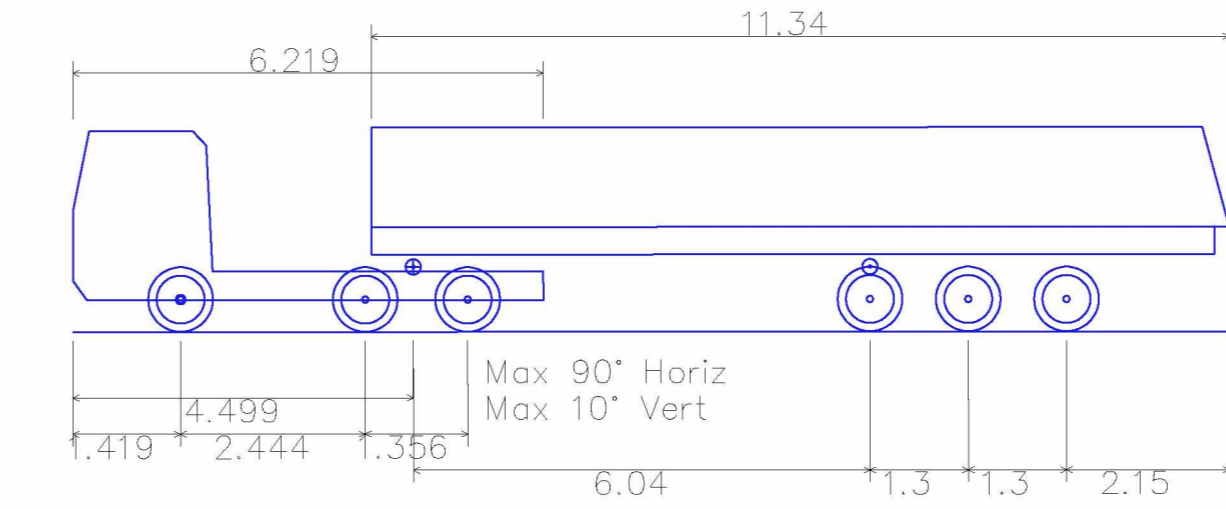
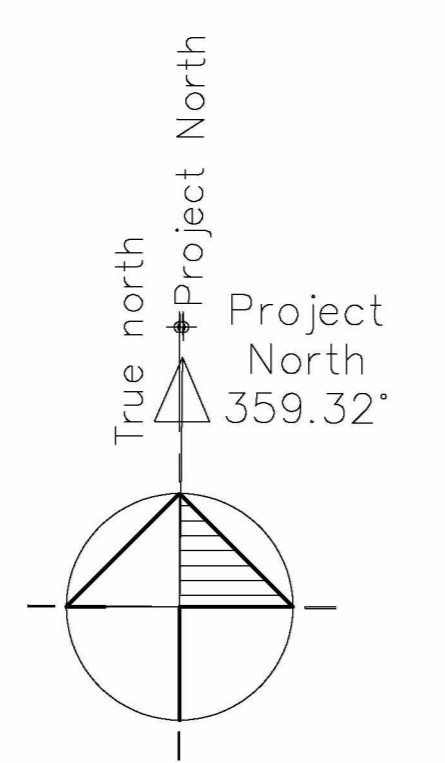
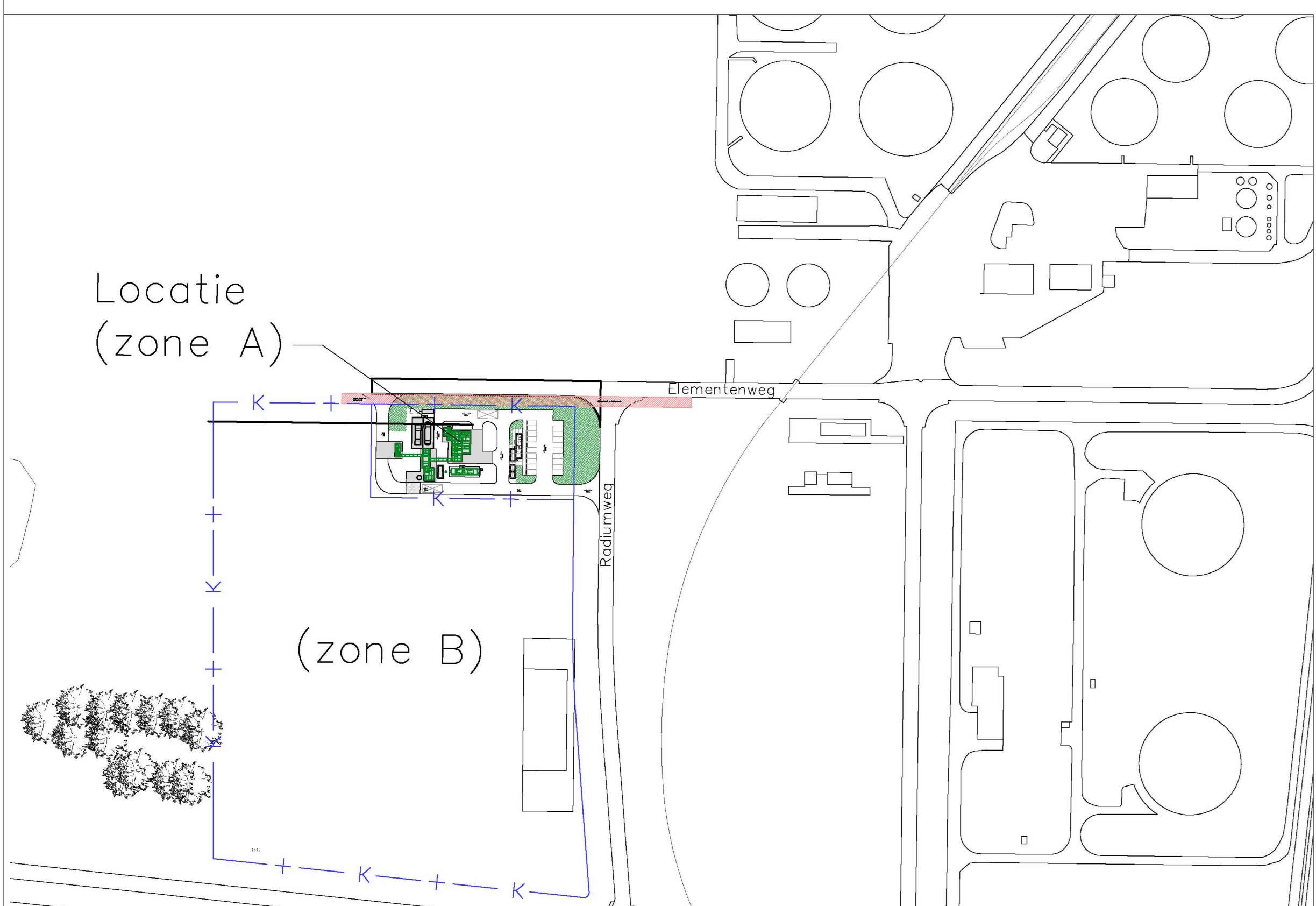

Tanker (Conform ASVV)
 Overall Length 15.289m

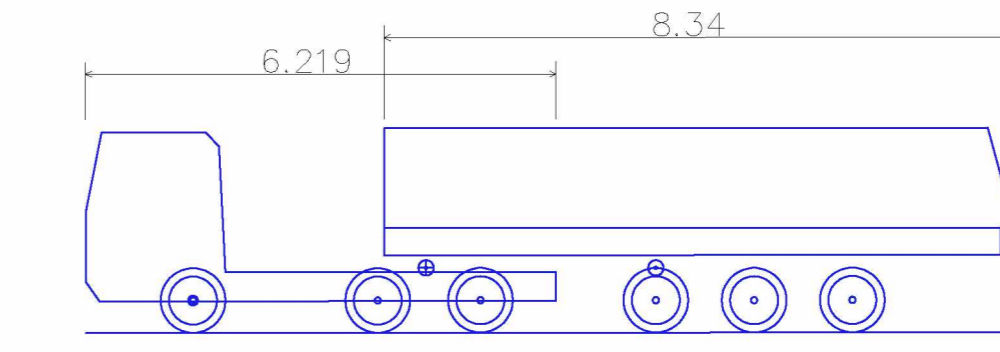

mover
 Overall Length 12.289m

D			
C			
B			
A	03-02-2023	Diverse wijzigingen	CvDS HvdL
0	24-11-2022	Vergunningsaanvraag	CvDS HvdL
Rev.	datum	Omschrijving	Get. Pres.
Opdrachtgever Alta Carbon Technologies			
Project ACT 1			
Onderwerp terrein overzicht			
Schaal	1:100	soort	Vergunningsaanvraag
Formaat	A4	status	Definitief
OR project nr.	210971	locatie	VA-B0001 A

